

## Zero Drop Solar Charger

Written by Administrator

Thursday, 11 October 2012 07:06 - Last Updated Friday, 31 May 2019 10:09

---

# ZERO DROP SOLAR CHARGER

MEDI's low cost zero drop solar chargers are available in various ranges 12V to 120V and 5A to 60A which is compatible with MEDI's inverter design and can be used with other inverter designs as well.

These chargers are called 'zero drop solar chargers' as they do not have any diode drop of 0.7V. This is a MOSFET based design which has very negligible voltage drop of 0.05V or less which means the loss is very less, ideal for solar applications.

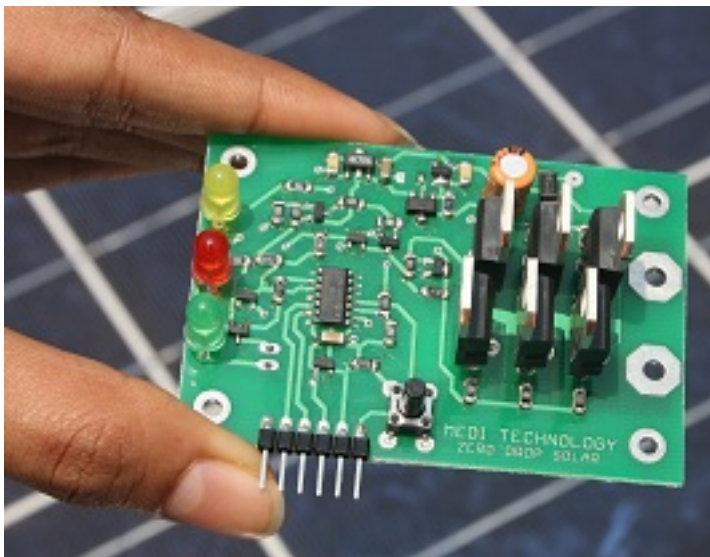

Since the drop is less, the losses are negligible so the efficiency achieved is  $> 99.5\%$ .

This is a micro-controller based charger, the micro-controller will sense the battery full charge voltage and will cut-off the battery when it reaches full charge. It will reconnect the battery if the battery drops to a preset level. The charger will also disconnect the panel from the battery, this is to avoid the reverse current flow from the battery to the panel during night. Moreover, if you connect the panel reverse, the micro-controller will not switch on the charger, similarly if you

## Zero Drop Solar Charger

Written by Administrator

Thursday, 11 October 2012 07:06 - Last Updated Friday, 31 May 2019 10:09

---

connect the battery reverse, the charger will not function. Battery reverse and panel reverse protections are incorporated in the design. If you connect both panel and battery reverse at the same time, the micro-controller will not switch on the charger. In all the above cases, the circuit will not damage and there will not be any current flow from the panel or battery.

MEDI has recently upgraded zero drop solar chargers to SMD version for 12V and 24V with a few improvements. The design has opto-coupler based signal sensing which makes it completely isolated and there will be no grounding issues. Two stage higher voltage regulator is incorporated in this design to withstand open circuit voltage of the panel.

The new SMD PCB is also smaller than our through-hole version.

### **Priority Solar Charging**

Our solar charger along with our inverter will have first priority solar charging. i.e, when it is charging from solar, it will not charge from the mains. Also, when it is charging from solar and battery is nearly full charged (for Medi Inverter this voltage is settable in menu), the inverter will start working by disconnecting the mains bypass. So the solar power will go to the load through inverter and also charge the battery (online function) if the solar current is more than the inverter current. If solar current is less than the inverter current, inverter will take the balance current from the battery. When the battery reaches the reserve charge (in Medi Inverter this value is settable), inverter will stop and mains will bypass, and the battery will be charged by solar. During nights, if the battery is not charged from the solar, battery will charge from the mains but only to a certain percent (in Medi Inverter this value is settable) so the next day the battery can be charged from solar. If the battery is fully charged using mains the previous night then the solar energy during the next day will be wasted. This way the first priority is always given to solar.

### **Using Medi solar chargers along with Other brand Inverters**

When using other brand inverters with Medi Solar chargers, the circuit below can be used for Auto mains disconnection (and inverter start) when battery is fully charged from Solar.

# Zero Drop Solar Charger

Written by Administrator

Thursday, 11 October 2012 07:06 - Last Updated Friday, 31 May 2019 10:09

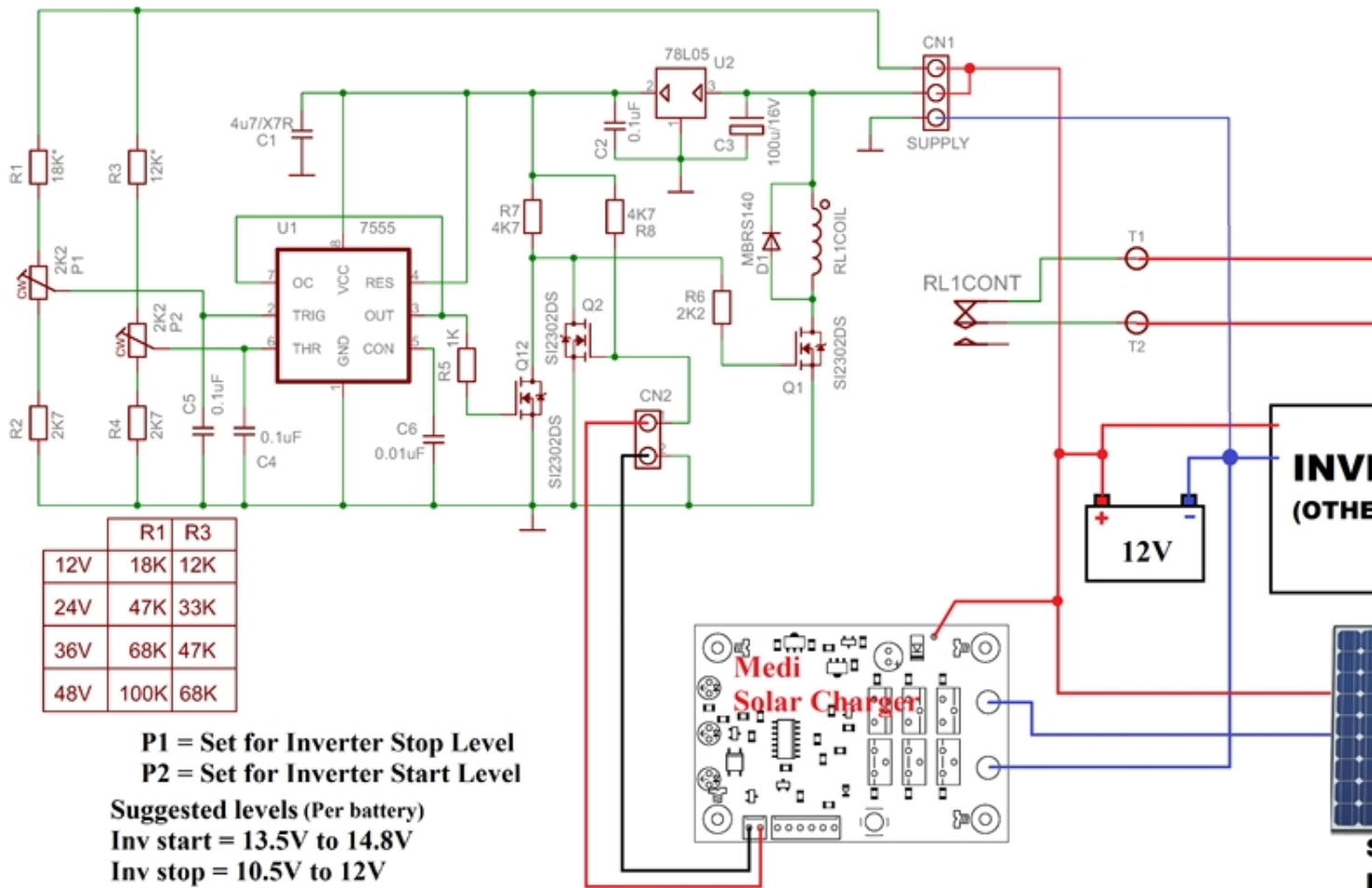

## CIRCUIT FOR AUTO MAINS DISCONNECTION (AND INV START) WHEN BATTERY FULLY CHARGED (WIRING FOR MEDI SOLAR CHARGERS (ZERO DROP / MPPT) WITH OTHER BRAND INVERTERS)

[Auto mains disconnection and inverter start circuit \(for using with other brand inverters\).](#) [More](#)

### Specification of Medi Zero Drop Solar Charger

- VOLTAGE 12V-96V
- CURRENT 10A - 80A
- EFFICIENCY > 99.5%
- PROTECTIONS AGAINST
  - Battery reverse
  - Panel reverse
  - Battery Overcharge (full charge cut-off level is settable)
  - Battery current reverse flow to panel (during nights)

### INDICATIONS

Battery reverse

Panel reverse

## Zero Drop Solar Charger

Written by Administrator

Thursday, 11 October 2012 07:06 - Last Updated Friday, 31 May 2019 10:09

---

### Charging

Opto-Coupler output for Charging Live indication

Zero Drop Solar Charger cost

<b>Model</b>	<b>Cost (INR)</b>
12V/10A	475
24V/10A	475
12V/24V/30A	750
12V/24V/60A	1000
36V to 96V/10A	2350
36V to 96V/25A	2850
36V to 96V/30A	3300
36V to 96V/40A	3500
36V to 96V/50A	3750
36V to 96V/60A	4300
36V to 96V/80A	4600

\*The minimum quantity of Zero Drop Solar Charger we supply is 5 nos.

NB: Please note that sales tax charges and delivery charges are exclusive.